

TREE GRATE HALVES BOLTED TOGETHER
w/ (2) 1/2-13 X 3 STNLS. STL. HEX.
BOLT AND HEX. NUT w/ WASHERS

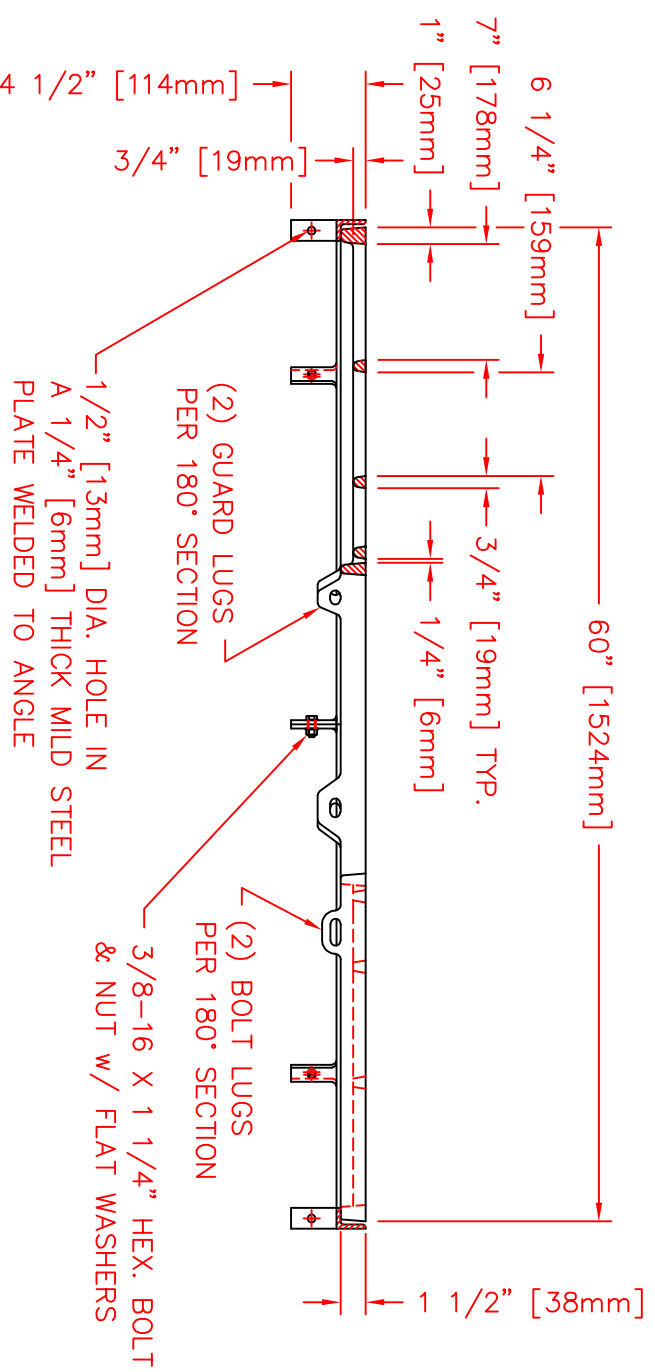

NOTE: ALL DIMENSIONS ARE SHOWN IN ENGLISH AND [METRIC].
COMPONENT NO'S: STEEL FRAME 9992-6038; (2) TREE GRATE 8870-0002
MATERIAL: FRAME - HOT ROLLED MILD STEEL ANGLE (L1 3/4 X 1 1/4 X 3/16)
GRATE - CAST GRAY IRON ASTM A-48, CLASS 35B
FINISH: NOT PAINTED
WEIGHT: 390#/SET

DR.	E. REMME	SCALE	TITLE:
CH.		1'-1'-0"	R-8870
APP.		DIM CHK.	TREE GRATE AND STEEL FRAME
DATE	3-29-96		NEENAH FOUNDRY COMPANY NEENAH WISCONSIN 54956