

BOLT LID TO FRAME w/
 (4) 1/2"-13 x 2 1/4" S.S. HEX BOLT,
 S.S. WASHER & NEOPRENE WASHER
 KIT NO. 92560

(2) CONCEALED PICK HOLES
 PER NF-42303

HEAT DATE

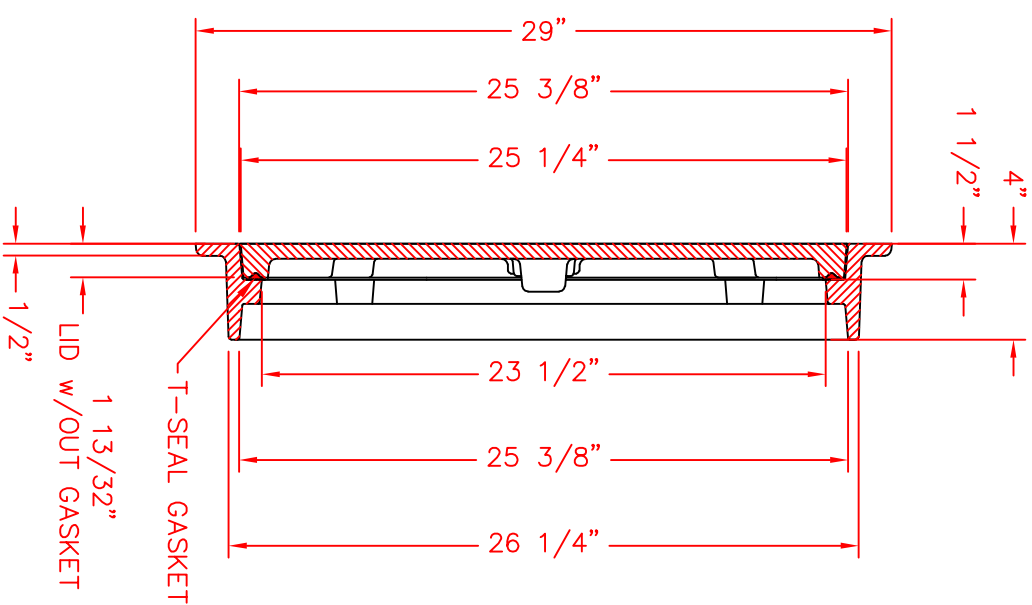

- NOTES:
- ALL DIMENSIONS SHOWN ARE IN ENGLISH
 - LOAD RATING: H-25 / HS-25
 - COMPONENT NOS.: FRAME 6461-0007, LID 6461-5293
 - MATERIAL: CAST GRAY IRON ASTM A-48, CLASS 35B
 - FINISH: NO PAINT
 - WEIGHT: FRAME ~76# LID ~100#

REV	DATE	DESCRIPTION	DR	CR	APP
1	XX-XX-XXXX	KXX			KXX/KXX/KXX

DR.	HSB	SCALE	TITLE:
CH.	RKB	1/8"=1"	R-6461-FH
APP.	JJF		BOLTED FRAME & LID
DATE	08-29-2019		
	www.nfco.com		
 NEENAH FOUNDRY NEENAH WISCONSIN 54956 PHONE 800-558-5075 LINCOLN, NEBRASKA 68529 PHONE 800-234-7466		NF-6461180	B