

3238 4000

1

B8

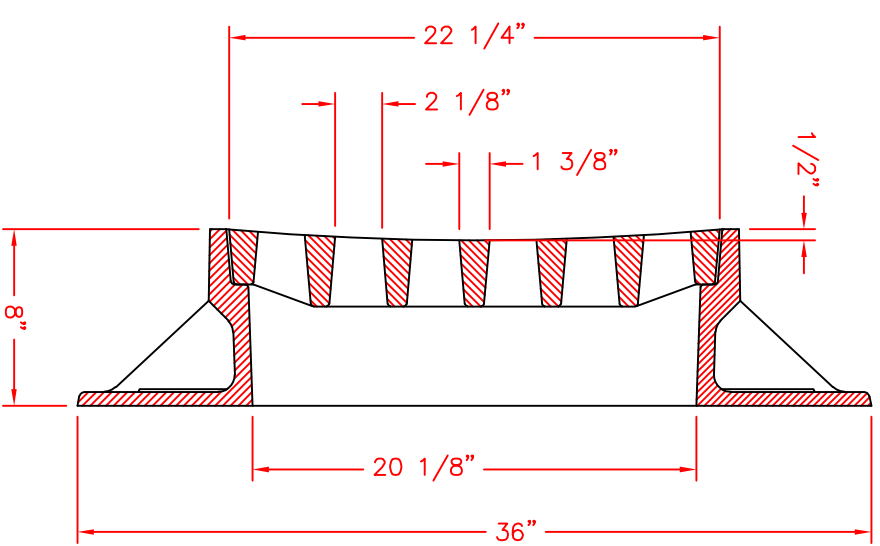
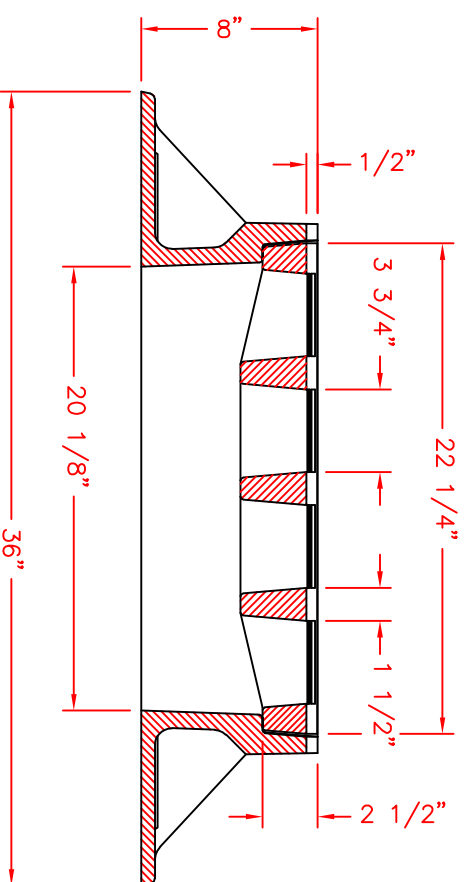
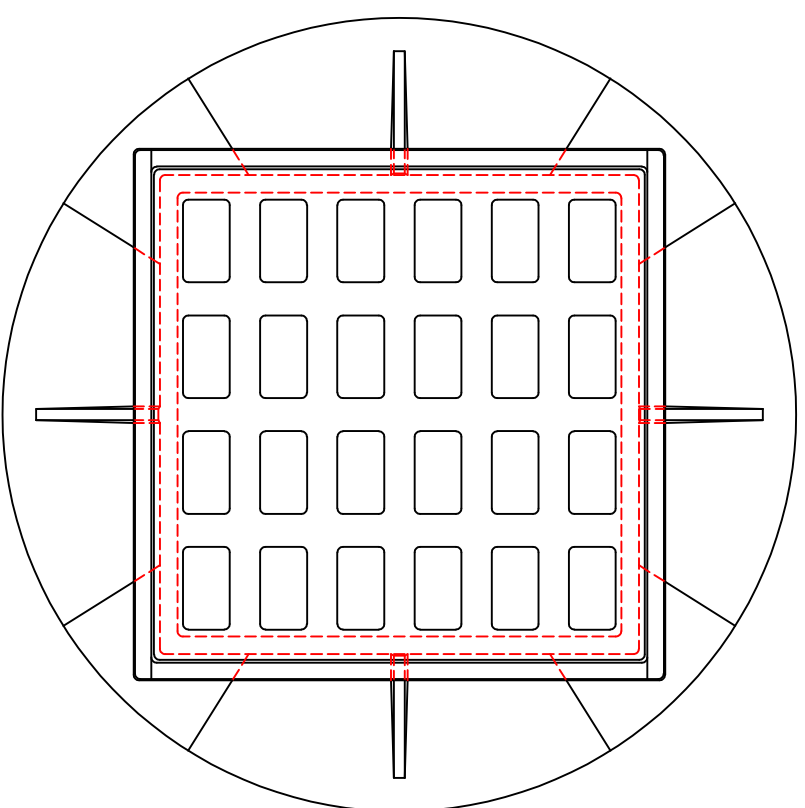

FREE OPEN AREA: 1.3 SQUARE FEET
 COMPONENT NO.'S: FRAME 3238-0001, GRATE 3238-0002
 MATERIAL: CAST GRAY IRON ASTM A-48, CLASS 35B
 FINISH: NOT PAINTED
 WEIGHT: FRAME 295 LBS., GRATE 178 LBS.

WAS NF-20887

DR.	E. NIVER	SCALE	TITLE:
CH.		1/8"=1"	FRAME AND TYPE "C" GRATE
APP.		DIM CHK.	NEENAH FOUNDRY COMPANY NEENAH WISCONSIN 54956
DATE	12-20-2010		NF-3238 400 B