

BOLT CURB BOX TO FRAME
w/ (2) 1/2-13 X 2 1/2 STEEL
HEX. BOLT, NUT, AND WASHER

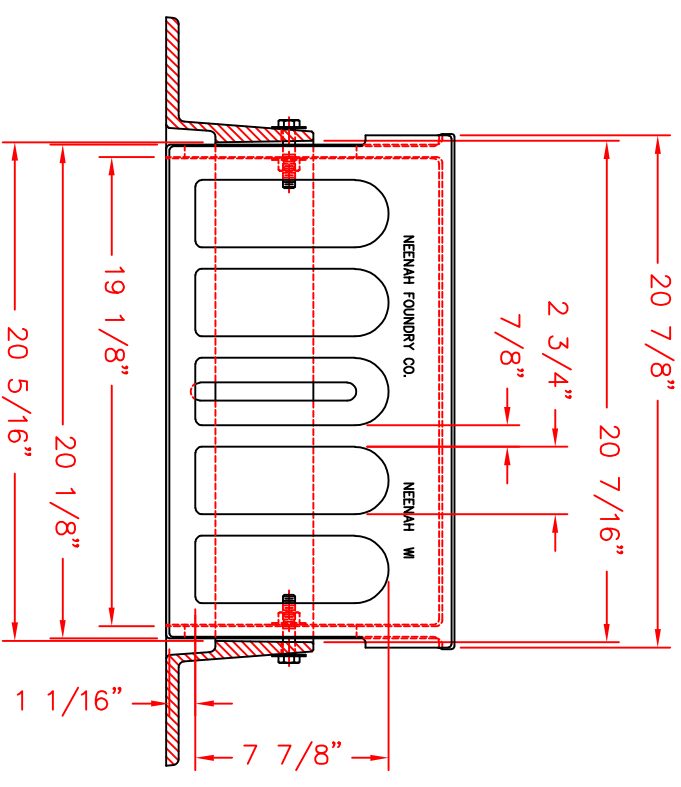
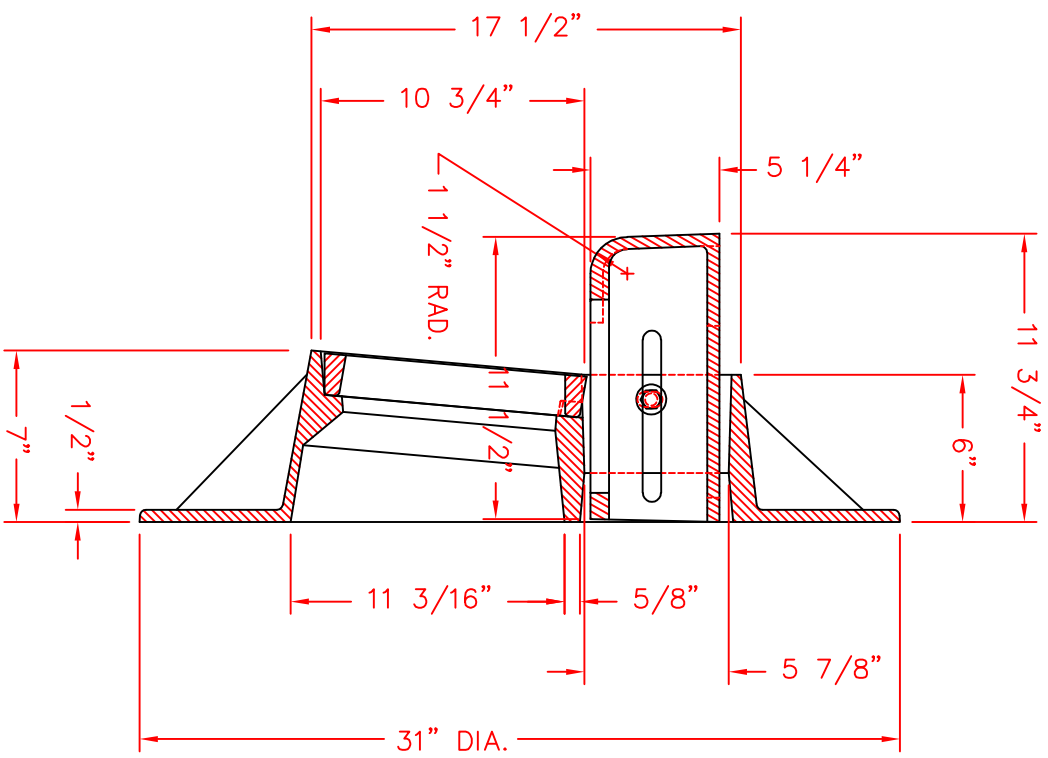
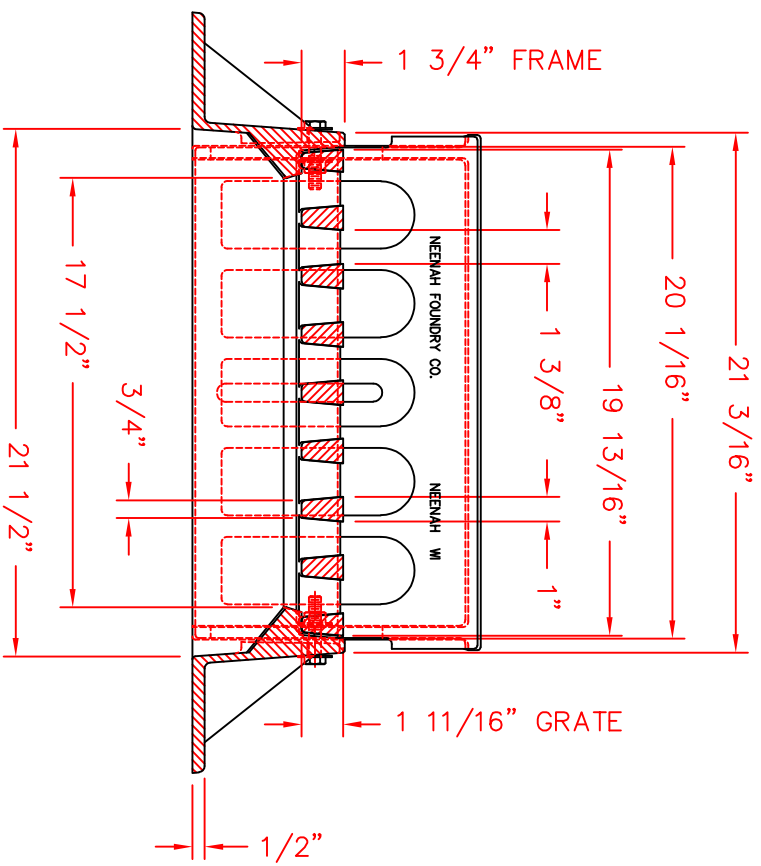
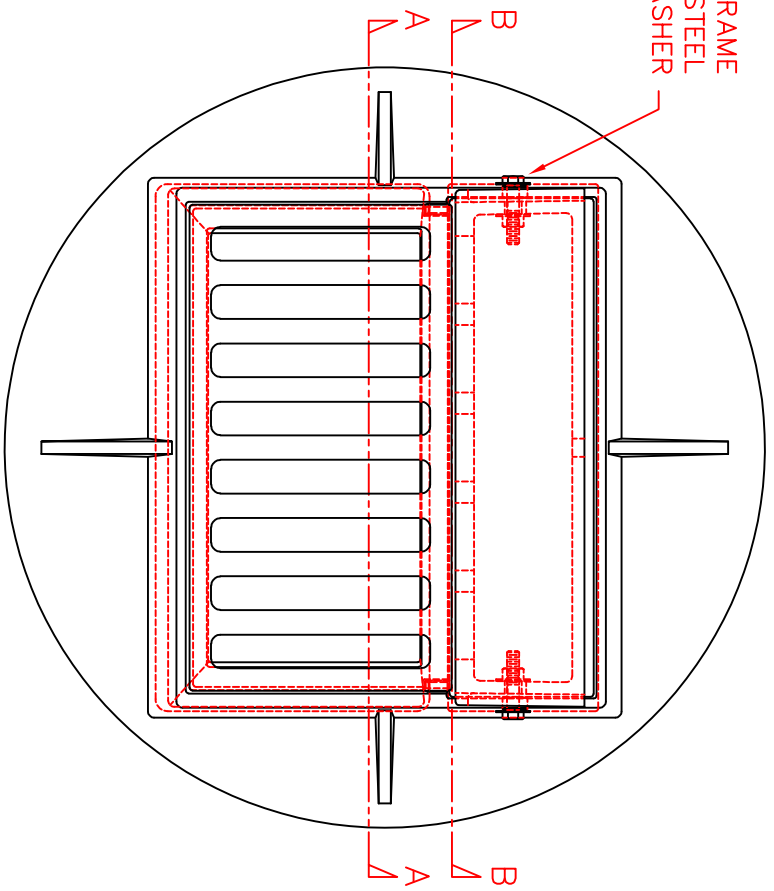

COMPONENT NO'S: FRAME 3170-0005, GRATE 3170-0002, CURB BOX 3070-0006
 MATERIAL: CAST GRAY IRON ASTM A-48, CLASS 35B
 FINISH: NO PAINT
 WEIGHTS: FRAME 198#, GRATE 45#, CURB BOX 71#

DR.	E. REMME	SCALE	1/8"=1"
CH.			
APP.		DIM. CHK.	
DATE	03-30-2006		
DATE	05-12-2009	CHANGED THE FRAME TO MATCH PATTERN	ELR
		REVISION	INT

TITLE: R-3170 CURB INLET
 FRAME, GRATE AND CURB BOX

NEENAH FOUNDRY COMPANY
 NEENAH WISCONSIN 54956

NE-3170 195 B