

(4) GUSSETS 90° APART  
SECTION B-B

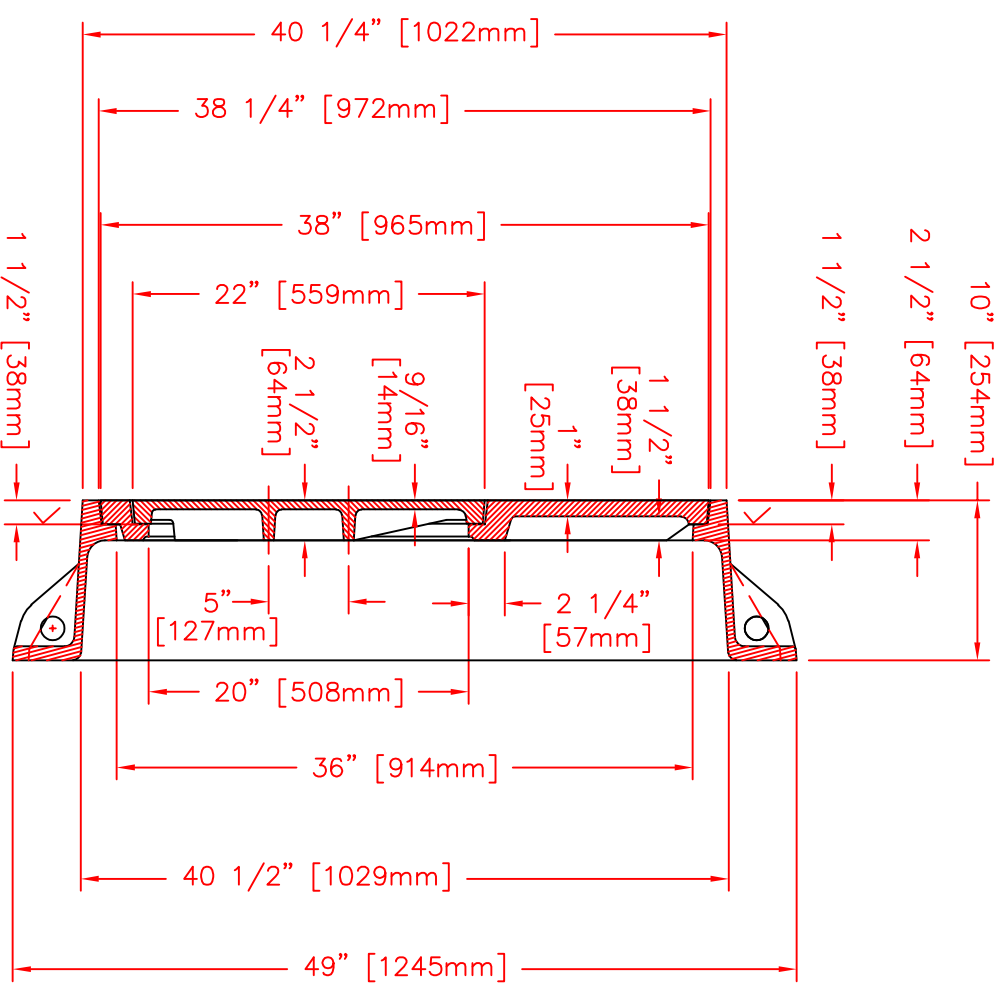

NOTE: ALL DIMENSIONS SHOWN ARE IN ENGLISH AND [METRIC]  
 COMPONENT NOS.: FRAME 1740-0006, OUTER LID 1741-0006, INNER LID 1090-0011  
 MATERIAL: CAST GRAY IRON ASTM A-48, CLASS 35B  
 FINISH: NO PAINT  
 WEIGHT: FRAME APPROX. 462, OUTER LID 282#, INNER LID 91#

DR.	CSK	SCALE	TITLE:	R-1741-D
CH.		1"=1'-0"	FRAME WITH DOUBLE LIDS	
APP.		DIM CHK.	NEENAH	
DATE	10-19-1993		FOUNDRY COMPANY	
			NEENAH WISCONSIN 54956	
			<b>INER</b>	
			NF-1741	
			600	
			B	